

Zero Piler SCZ-ECO600S

Super Crush Mode

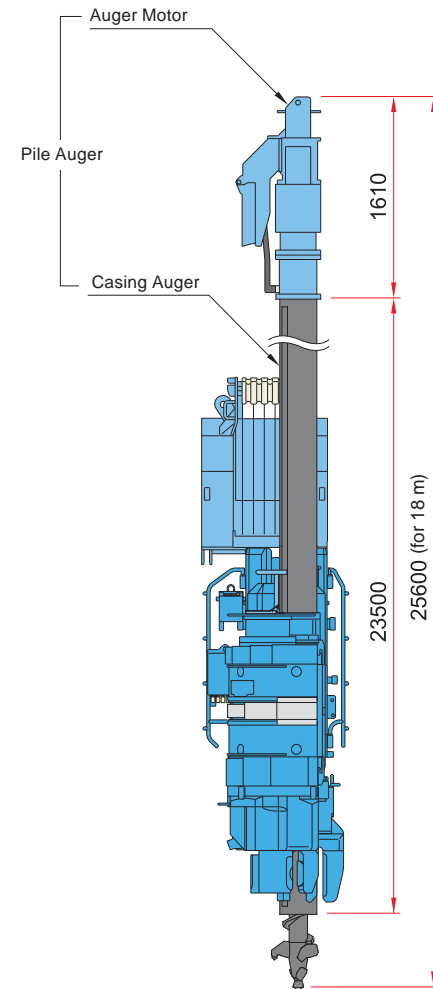

Zero Piler SCZ-ECO600S

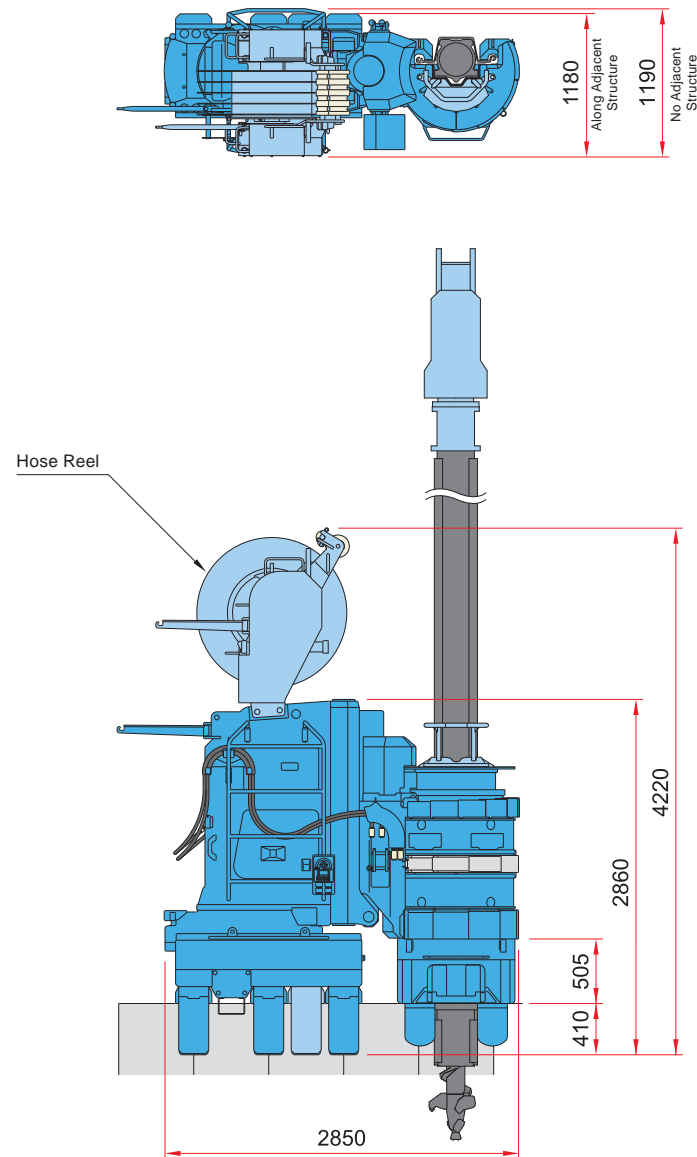

Zero Piler	SCZ-ECO600S
Applicable sheet piles	SM-J(600 mm)
Max. Press-in Force	770 KN (79 t)
Max. Extraction Force	1000 KN (102 t)
Stroke	1000 mm
Press-in Speed	1.5~40.0 m/min
Extraction Speed	2.5~35.0 m/min
Control System	Radio Control
Movement	Self-Moving
Mass	3 Clamps 12440 kg 4 Clamps 12840 kg

Pile Auger	PA17
Applicable pile length	Max. 18.0 m
Mass	Auger Motor 760 kg Casing Auger 5980 kg (for 18 m)
Total Mass	6740 kg (for 18 m)
Hose Reel	HR12
Mass	1500 kg

* 3 Clamps are used pressing in along adjacent structure, and 4 Clamps are used pressing in no adjacent structure.

Water Jetting Mode



*Piler Jet Reel is an optional item.

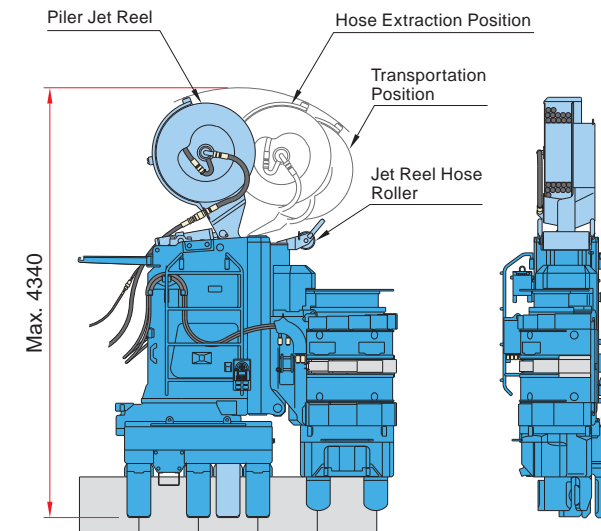

Piler Jet Reel	JR27
Applicable pile length	Standard 17.0 m (Max. 27 m)
Mass	780 kg
Jet Reel Hose Roller	
Mass	60 kg

Standard Mode

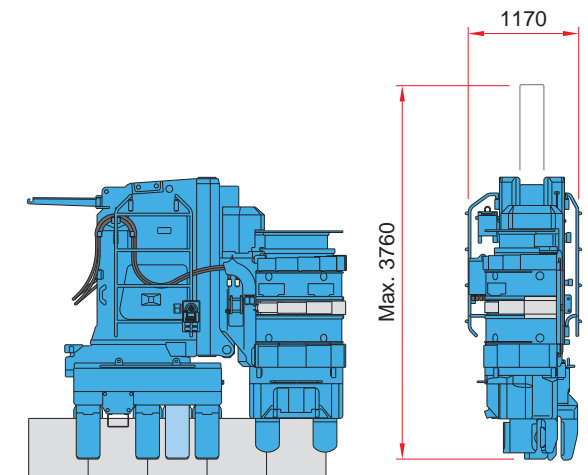

• Total Mass		
Super Crush Mode		
• The Press-in Machine Itself	3 Clamps	13960 kg
• Hose reel	4 Clamps	14360 kg
• Hoisting Bracket		
Water Jetting mode		
• The Press-in Machine Itself	3 Clamps	13300 kg
• Piler Jet Reel		
• Jet Reel Hose Roller	4 Clamps	13700 kg
• Hoisting Bracket		

* If the Silent Piler is hoisted at site, hoisting bracket(20 kg) is needed.

Power Unit

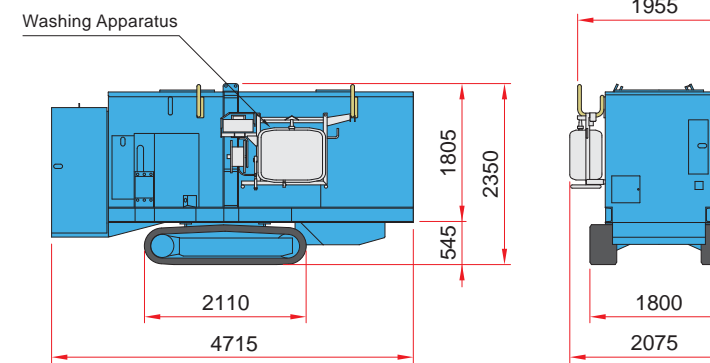

Power Unit	EU300G3
Power Source	Diesel Engine
Rated Power Output	Power Mode 230 kW (313 ps) /1800 min ⁻¹ Eco Mode 204 kW (277 ps) /1600 min ⁻¹
Fuel Tank Capacity	500 L
Hydraulic Oil Tank Capacity	Piler ECO Oil 630 L
Moving Speed	1.4 km/h
Mass	8250 kg

Reaction Stand

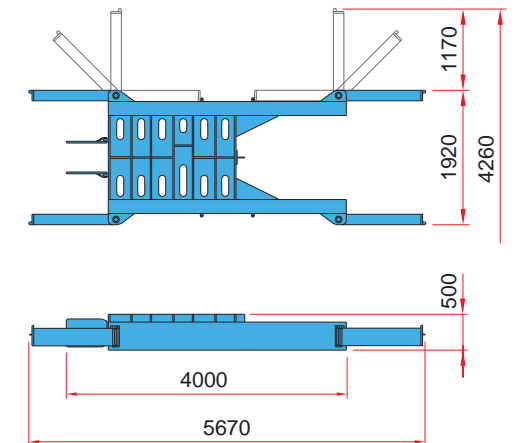

Reaction Stand	
Mass	2100 kg

Specifications are subject to alteration without prior notice.