

COMBI-GYRO WALL SYSTEM

- High Modulus Steel Combined Wall -

Ver. Tube / Hat Wall Vol.2 Construction

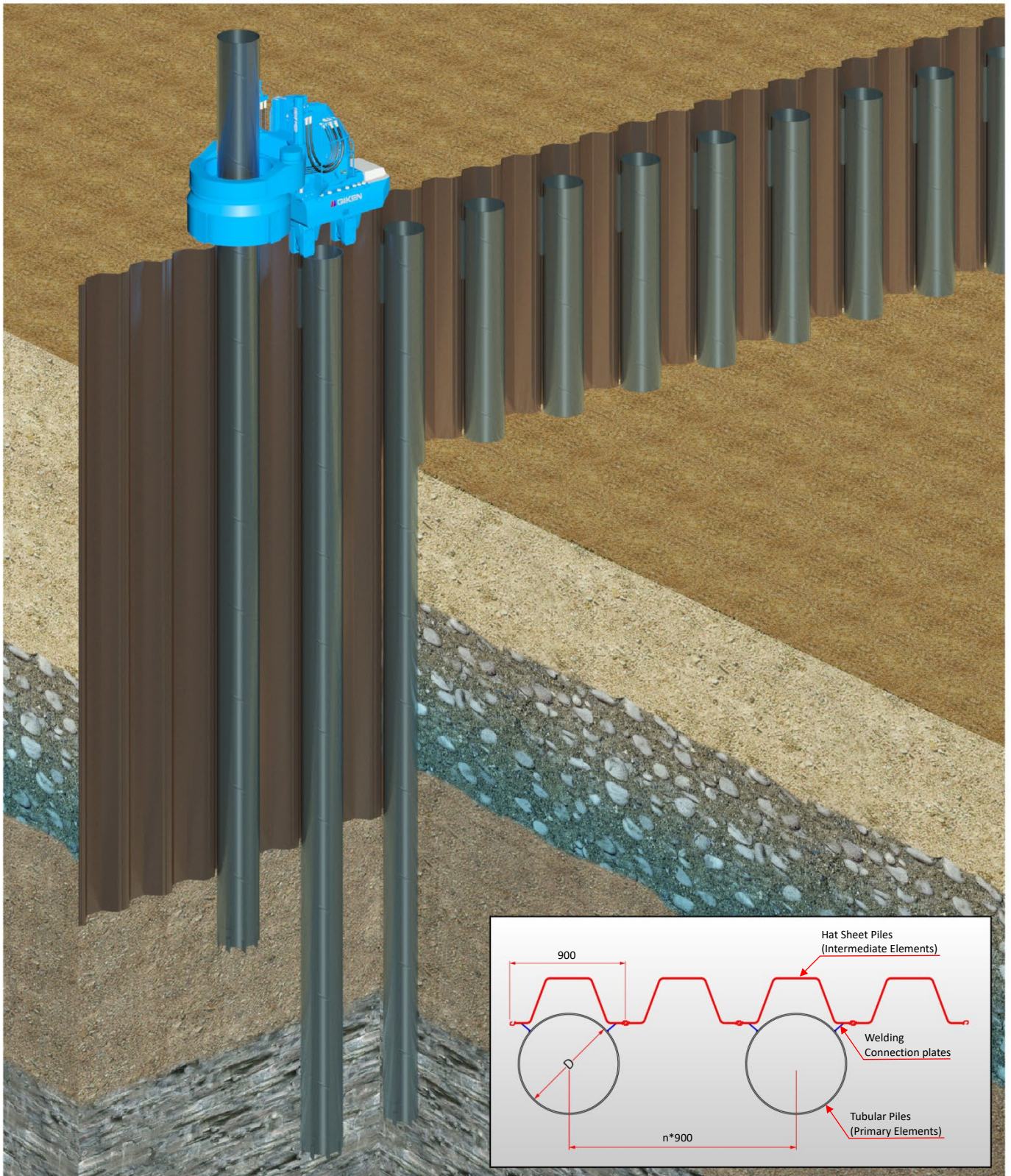

Table of Contents

| | | |
|-----------|---|----|
| Chapter 1 | Introduction | 1 |
| Chapter2 | Standard Procedure | 2 |
| | 2-1 Overall Procedure | 2 |
| | 2-2 Initial Piling (Sheet Pile) | 3 |
| | 2-3 Installation Working Procedure (Sheet Pile) | 4 |
| | 2-4 Installation Working Procedure (Tubular Pile) | 5 |
| | 2-5 Extraction Working Procedure (Sheet Pile) | 6 |
| | 2-6 Extraction Working Procedure (Tubular Pile) | 7 |
| Chapter3 | Work Layout | 8 |
| | 3-1 Standard Operation of Sheet Piling (Above Ground) | 8 |
| | 3-2 Standard Operation of Tubular Piling (Above Ground) | 9 |
| | 3-3 Standard Operation of Sheet Piling (Above Water) | 10 |
| | 3-4 Standard Operation of Tubular Piling (Above Water) | 11 |
| | 3-5 GRB Operation (Non-staging Method) | 12 |
| Chapter4 | Machine Specification | 13 |
| | 4-1 Machine Specification | 13 |

Chapter 1 Introduction

The purpose of this document is to provide practical guidelines for the construction of the Combi-Gyro Wall.

The intended audience for this document is engineers and construction specialists involved in the design, construction, and contracting of foundation elements for infrastructures.

The press-in piling method is commonly used worldwide because of its very quiet operation, ultra low vibration, and flexibility of sizes to suit different wall properties and subsoil conditions.

The main attributes of the Combi-Gyro Wall are efficiency of physical wall properties and reusability. The Combi-Gyro Wall comprises steel tubular piles as the primary element and steel sheet piles as the secondary element. The efficiencies of physical wall properties can be optimised in view of the flexibility of pile size and the spacing of tubular piles for the ground conditions and the form of the loading. The Combi-Gyro Wall is installed by the press-in method and pile penetration force is monitored and recorded throughout the piling operation. This thorough monitoring and recording system alleviates concerns of quality control, as well as providing a comprehensive quality control method for a performance-based contracting process.

This document provides a description of construction equipment and procedures of the Combi-Gyro Wall.

Chapter 2 Standard Procedure

2-1 Overall Procedure

2-1-1 Installation of Sheet Piles

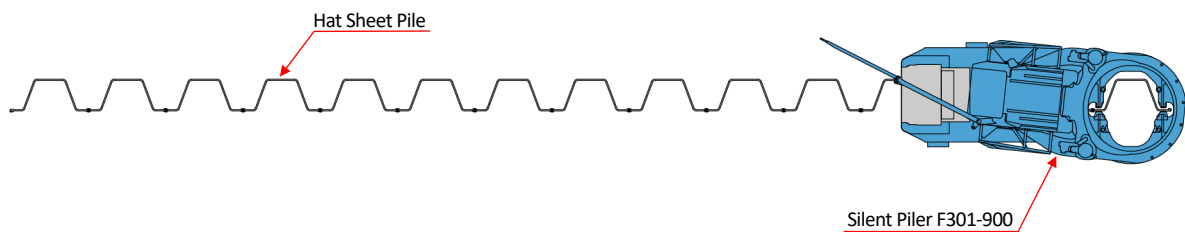

2-1-2 Installation of Tubular Piles

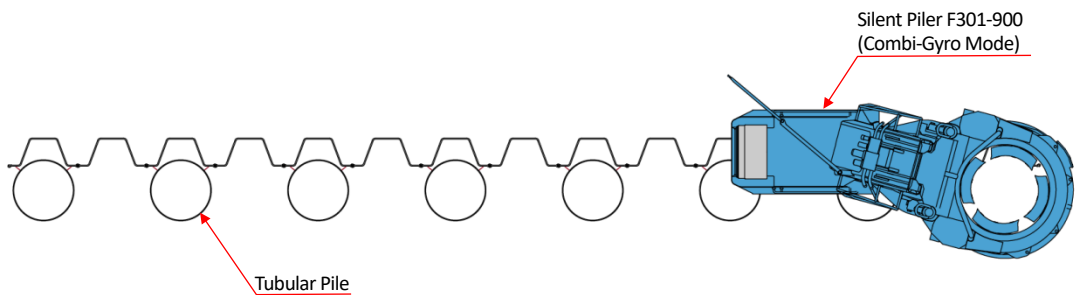

2-1-3 Joining Tubular Piles and Sheet Piles by Welding

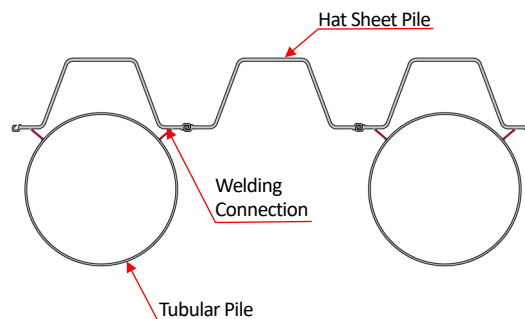

2-2 Initial Piling (Sheet Pile)

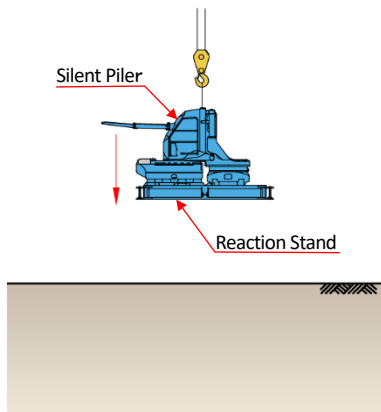

1. Setting of Silent Piler and Reaction Stand on level ground

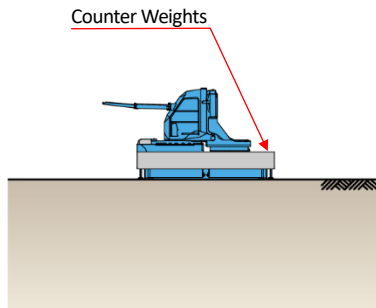

2. Loading of counter weights

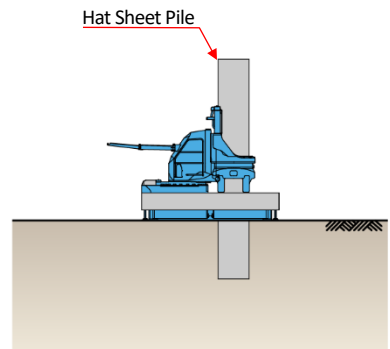

3. Pitching and installing of first pile

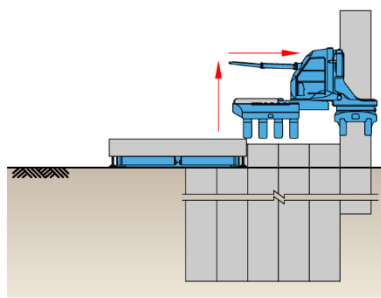

4. Installing of piles until Silent Piler can operate solely on reaction piles

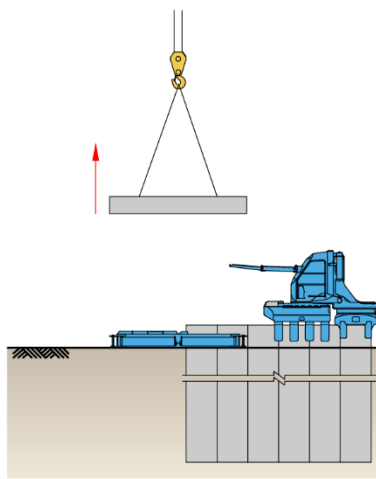

5. Removing of counter weights

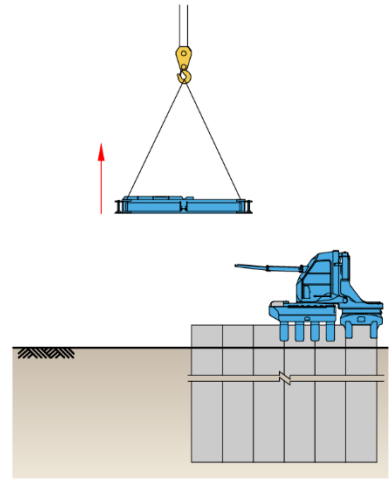

8. Removing of Reaction Stand and initial piling is completed

2-3 Installation Working Procedure (Sheet Pile)

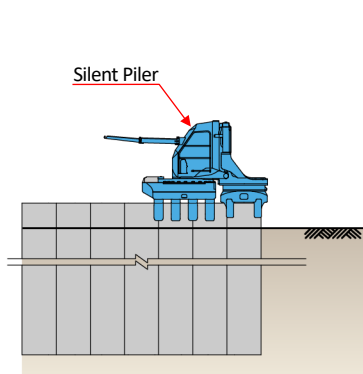

1. Installing of pile to prescribed depth

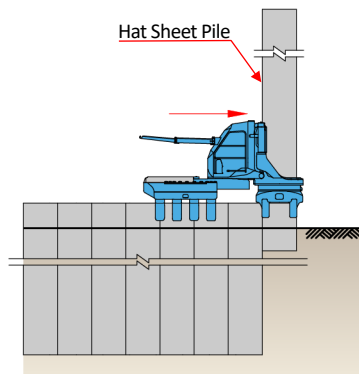

2. Pitching and installation of next pile

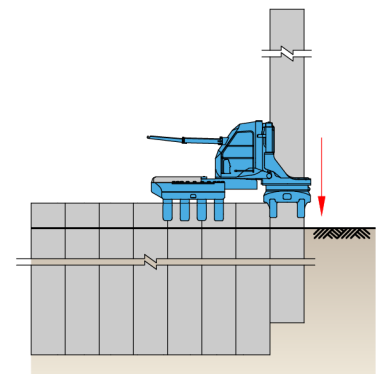

3. Installing of pile until the pile has sufficient bearing capacity

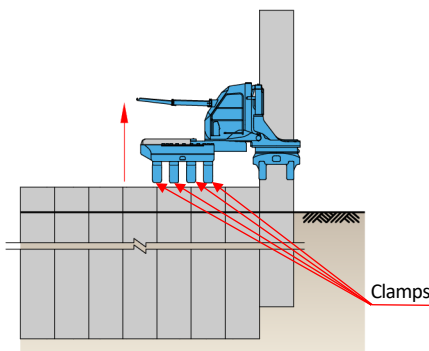

4. Releasing of clamps and raising machine body

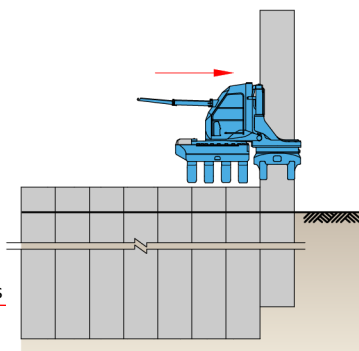

5. Moving of machine body forward

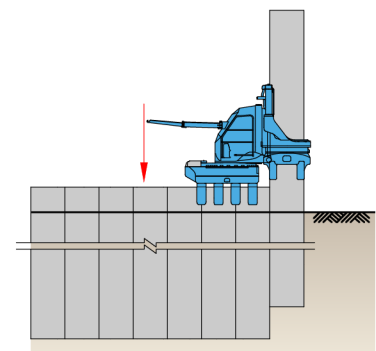

6. Lowering of machine body and gripping reaction piles

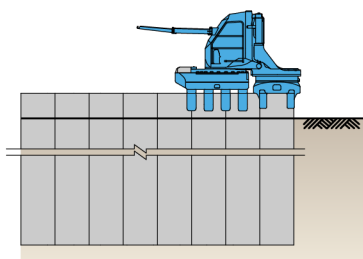

7. Completion of pile installation

2-4 Installation Working Procedure (Tubular Pile)

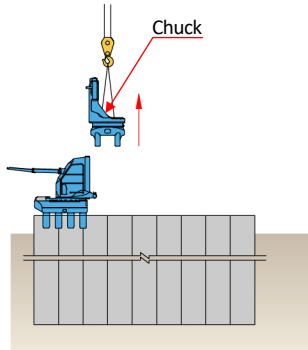

1. Dismantling of Chuck from Mast

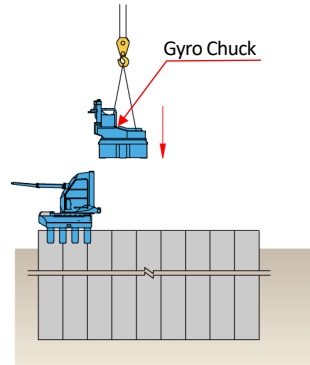

2. Fixing of Gyro Chuck to Mast

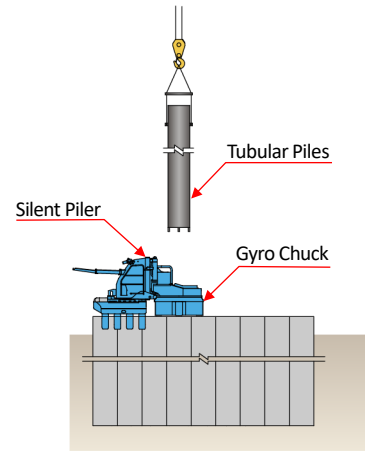

3. Pitching of tubular pile into Chuck

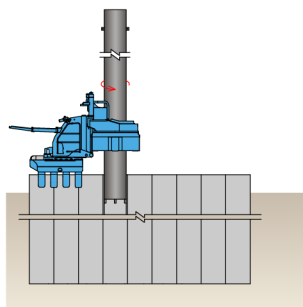

4. Installing of pile until top of pile reaches Chuck level

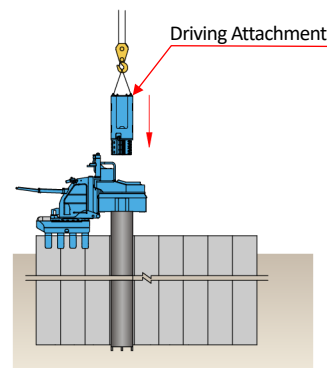

5. Pitching of Driving Attachment into top of pile and installing pile to prescribed depth

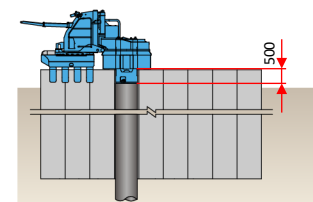

6. Pitching of Driving Attachment onto top of pile and installing pile to prescribed depth

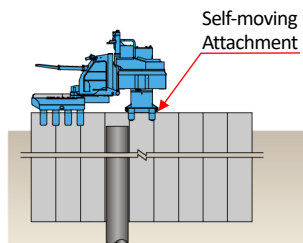

7. Pitching of Self-moving Attachment onto top of sheet pile located directly ahead of installed tubular pile

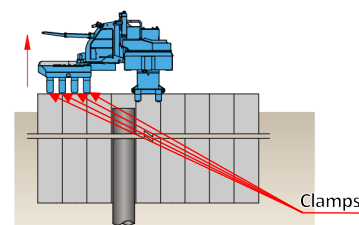

8. Fixing of Driving Attachment to Self-moving Attachment .
Releasing of Clamps and raising machine body

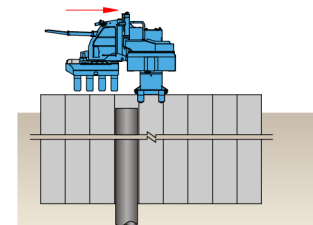

9. Moving of machine body forward

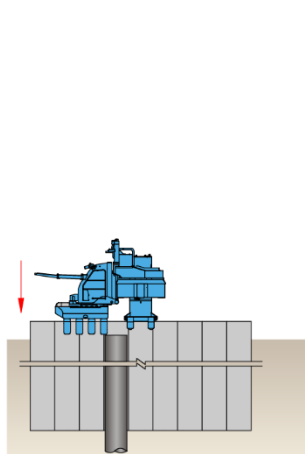

10. Lowering of machine body and gripping reaction piles
Repeat self-moving until next desired tubular pile installation position

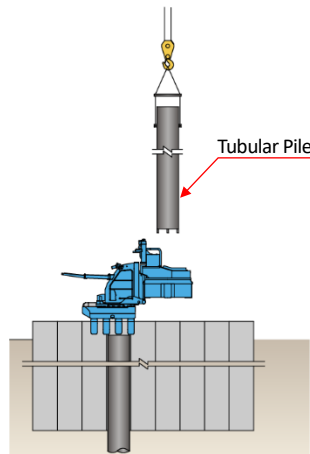

11. Repeat tubular pile installation and Self-moving until completion

2-5 Extraction Working Procedure (Sheet Pile)

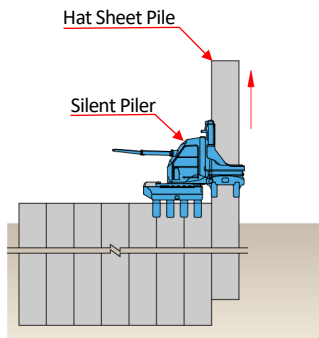

1. Partial extraction of sheet pile with Silent Piler

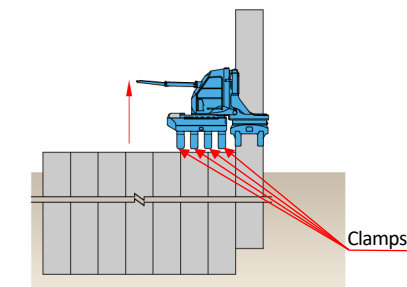

2. Releasing of Clamps and raising machine body

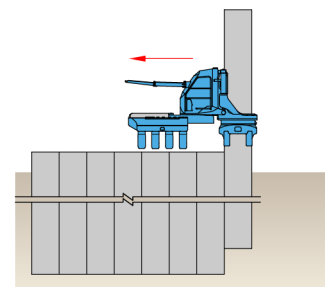

3. Moving of machine body rearward

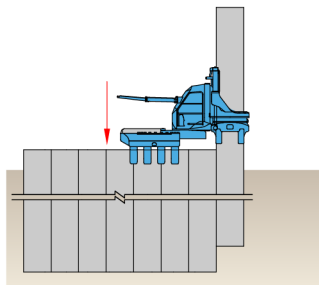

4. Lowering of machine body and gripping reaction piles

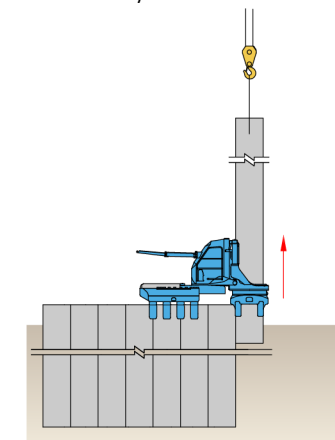

5. Completion of pile extraction

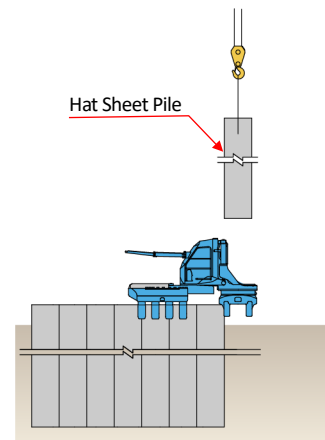

6. Handling and stacking of sheet pile
Repeat 1 to 6 until completion

2-6 Extraction Working Procedure (Tubular Pile)

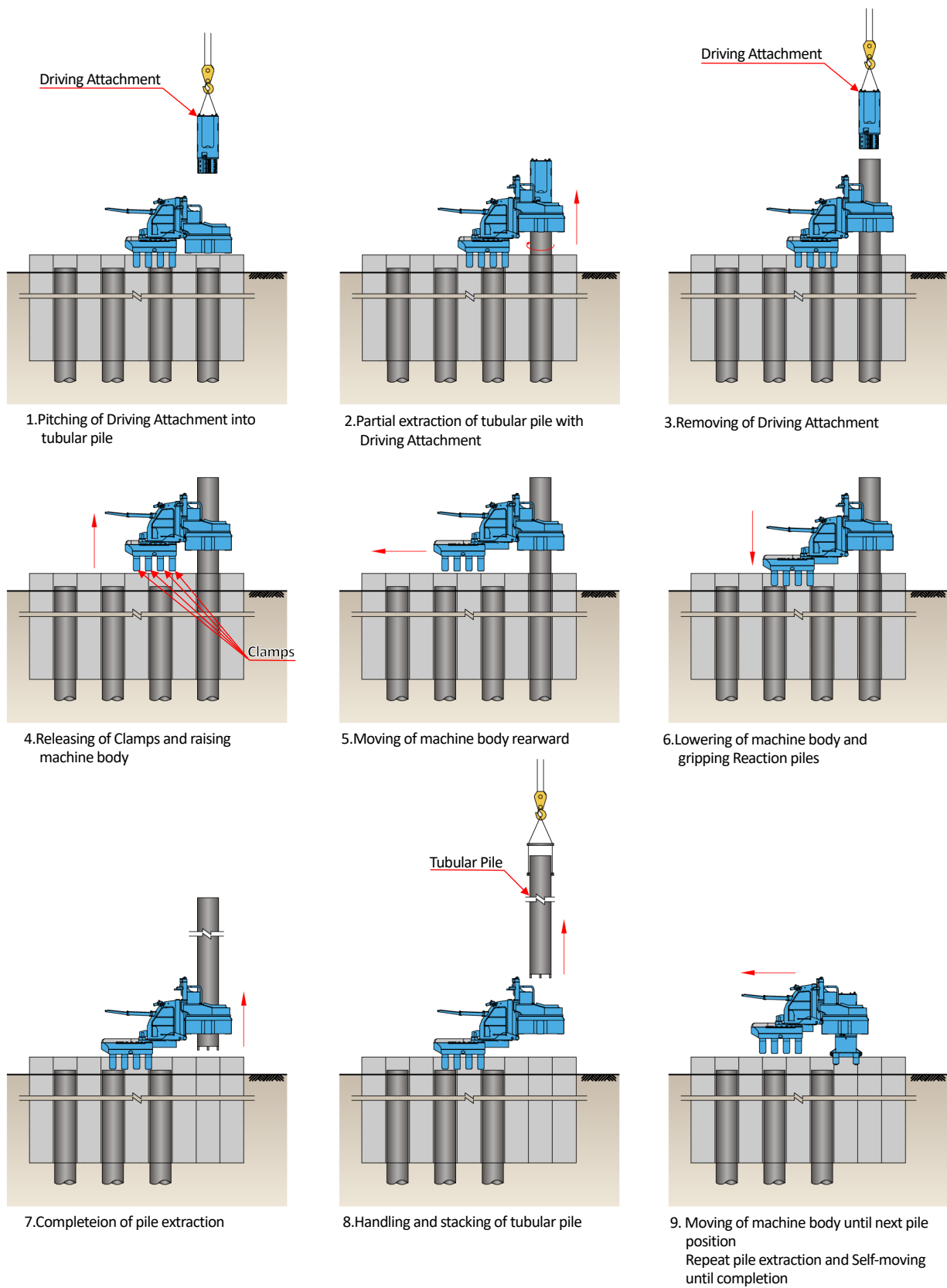

Chapter 3 Work Layout

3-1 Standard Operation of Sheet Piling (Above Ground)

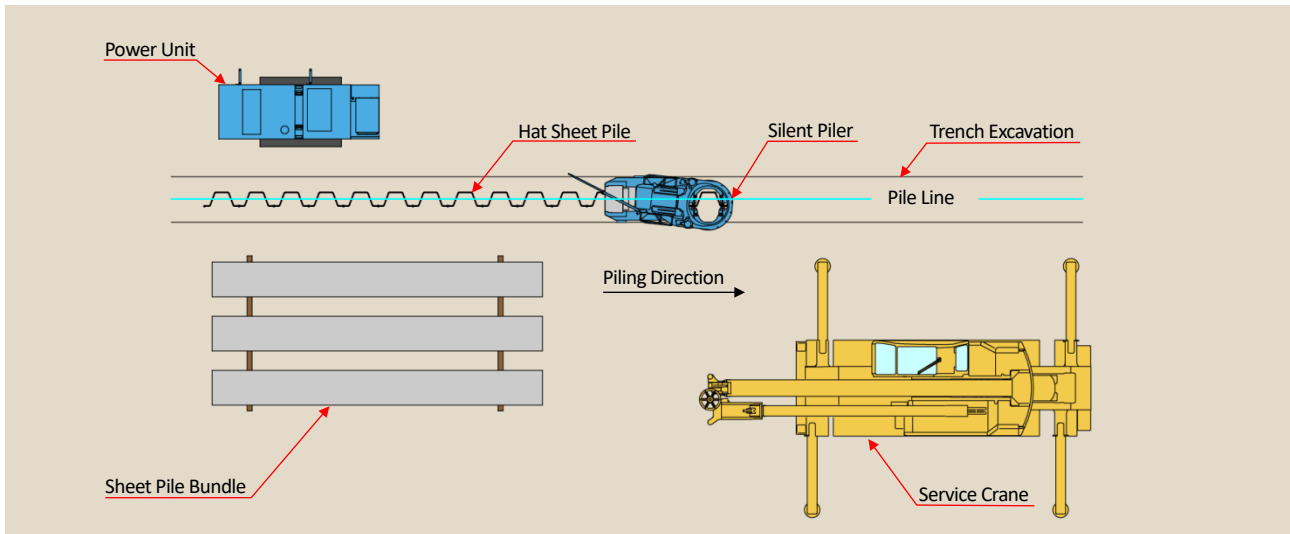

Plan View

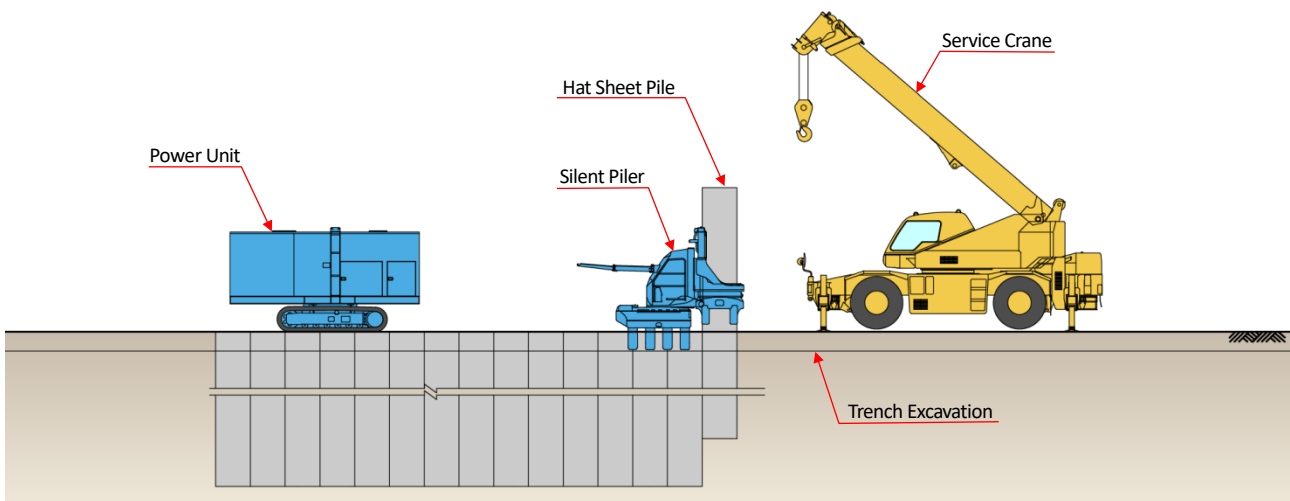

Sectional View

3-2 Standard Operation of Tubular Piling (Above Ground)

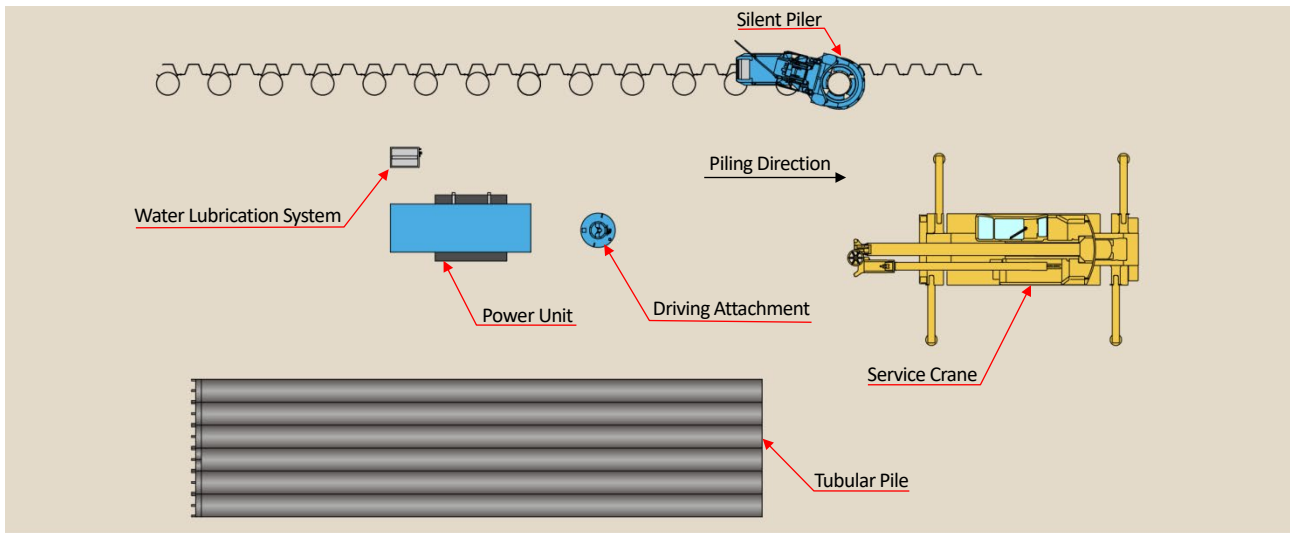

Plan View

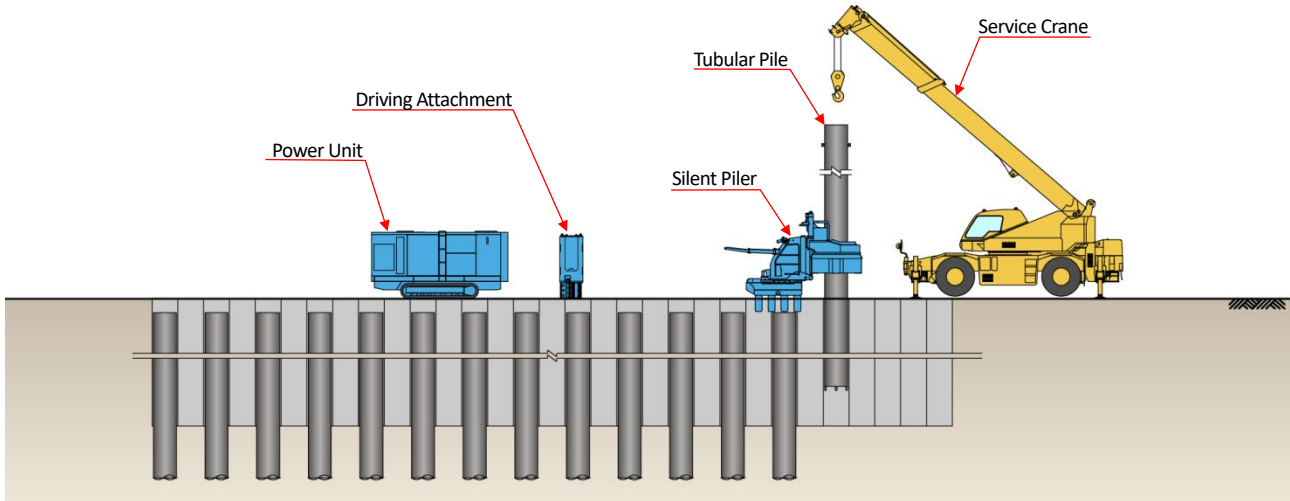

Sectional View

3-3 Standard Operation of Sheet Piling (Above Water)

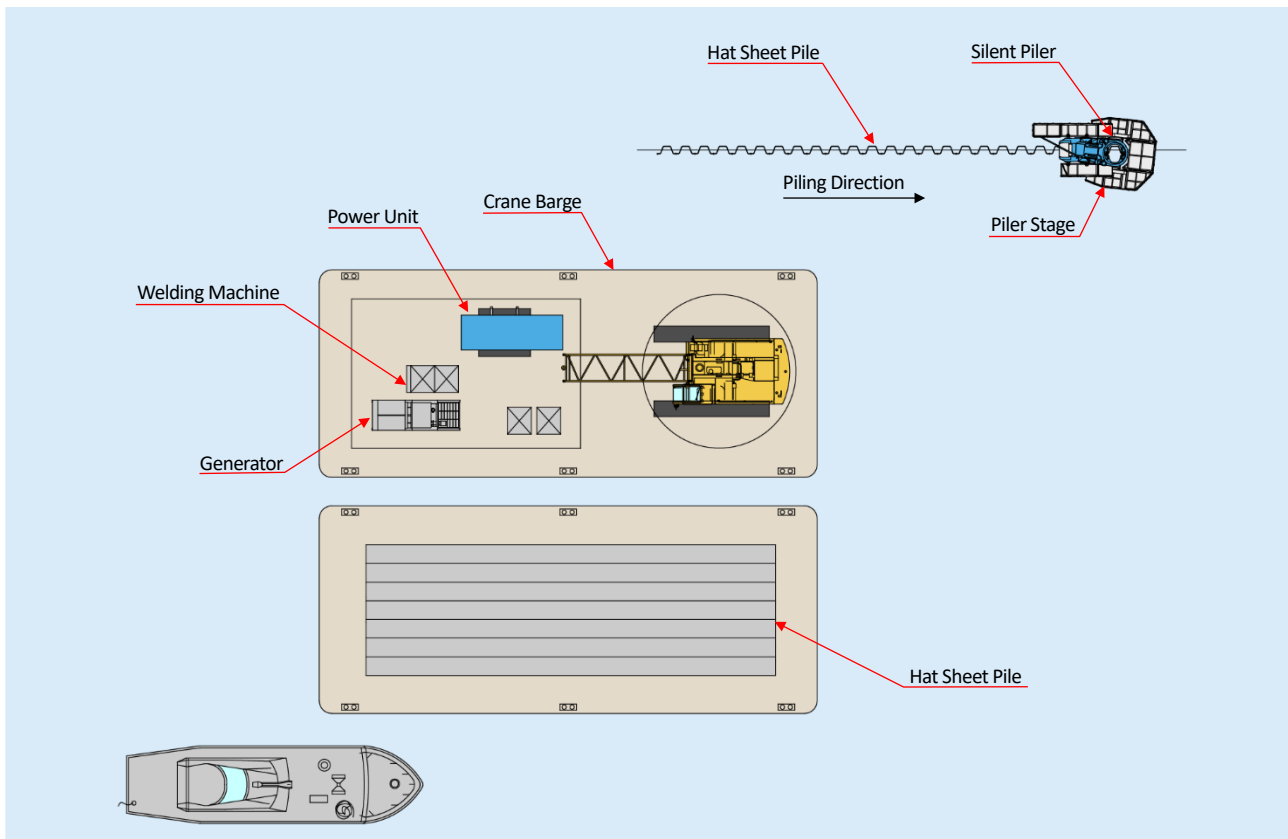

Plan View

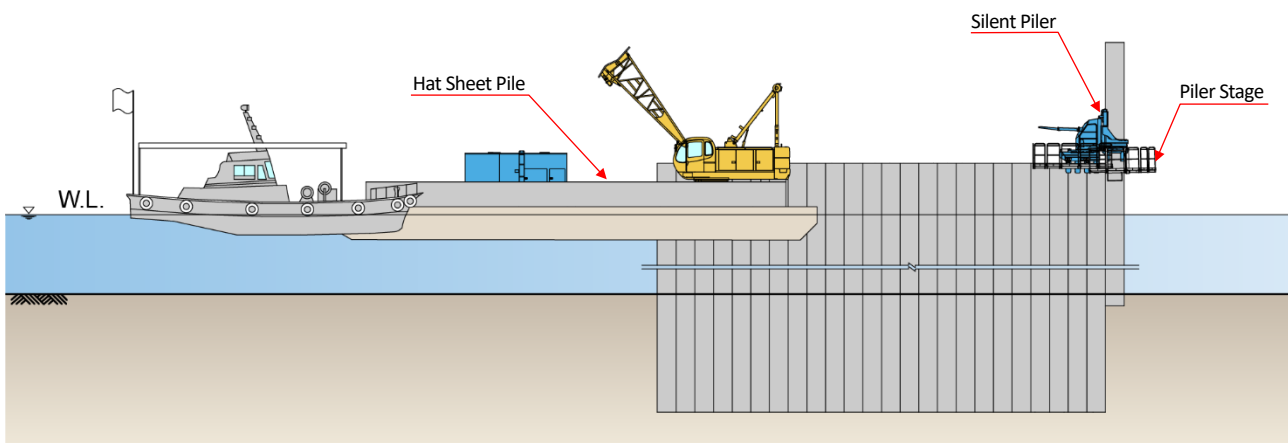

Sectional View

3-4 Standard Operation of Tubular Piling (Above Water)

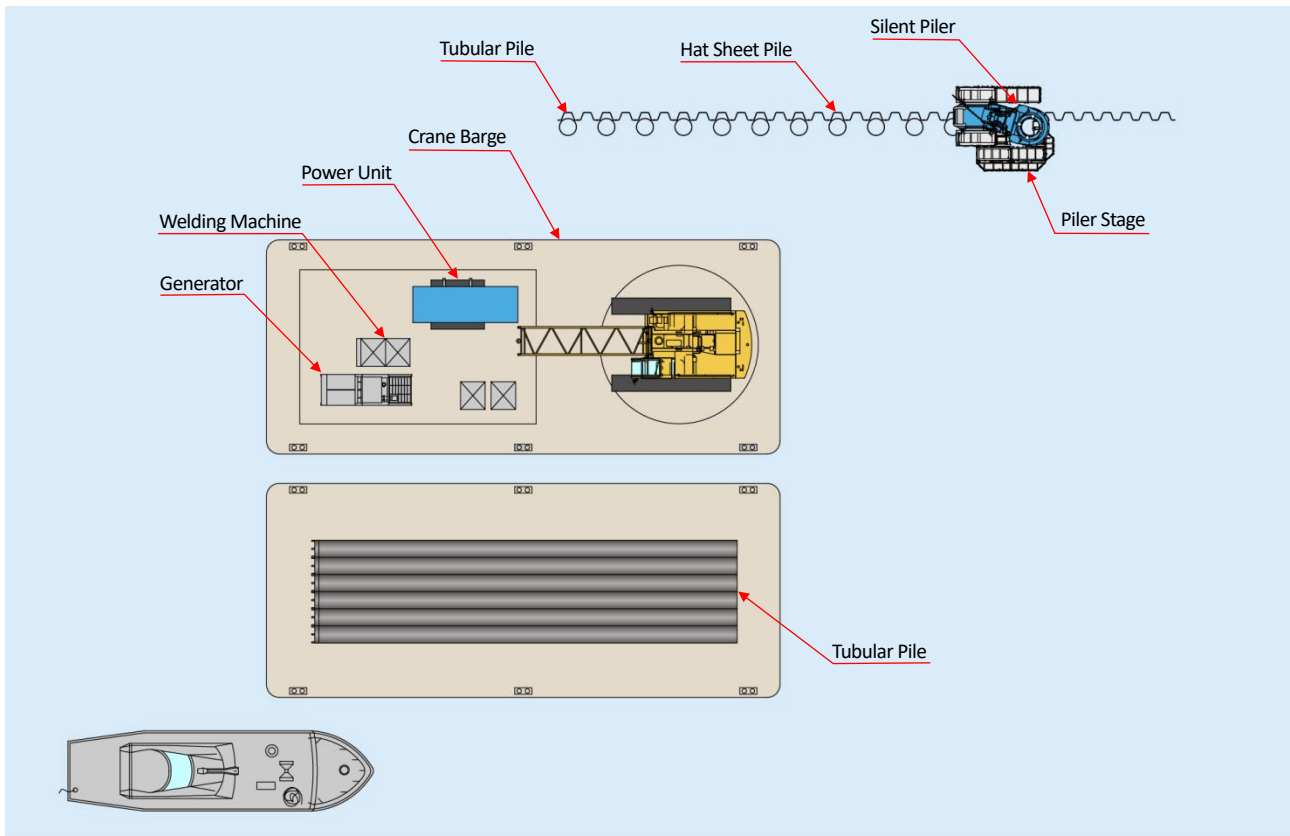

Plan View

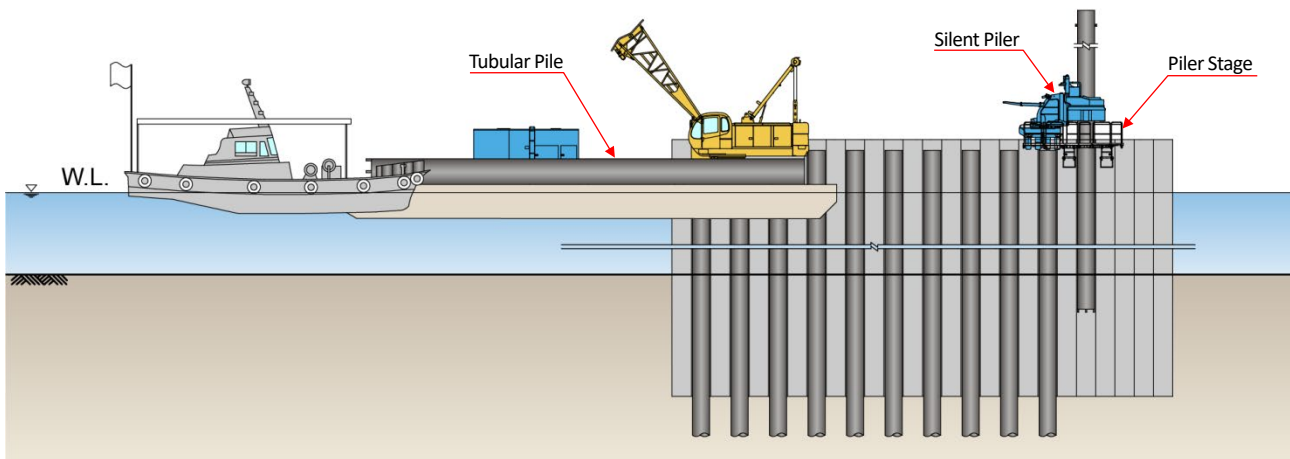

Sectional View

3-5 GRB Operation (Non-staging Method)

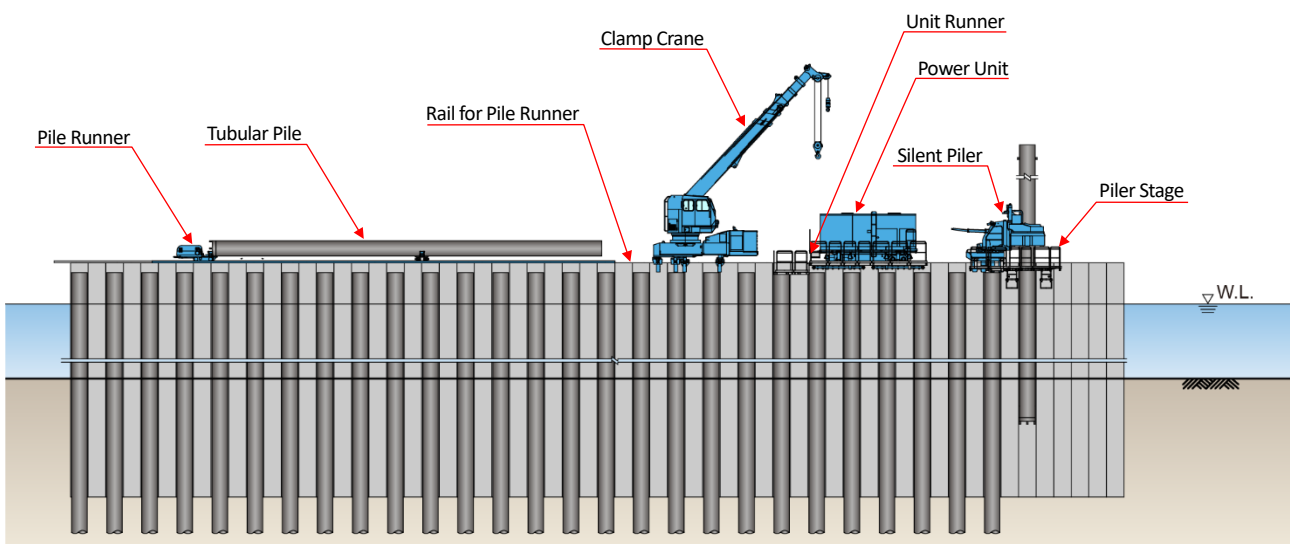
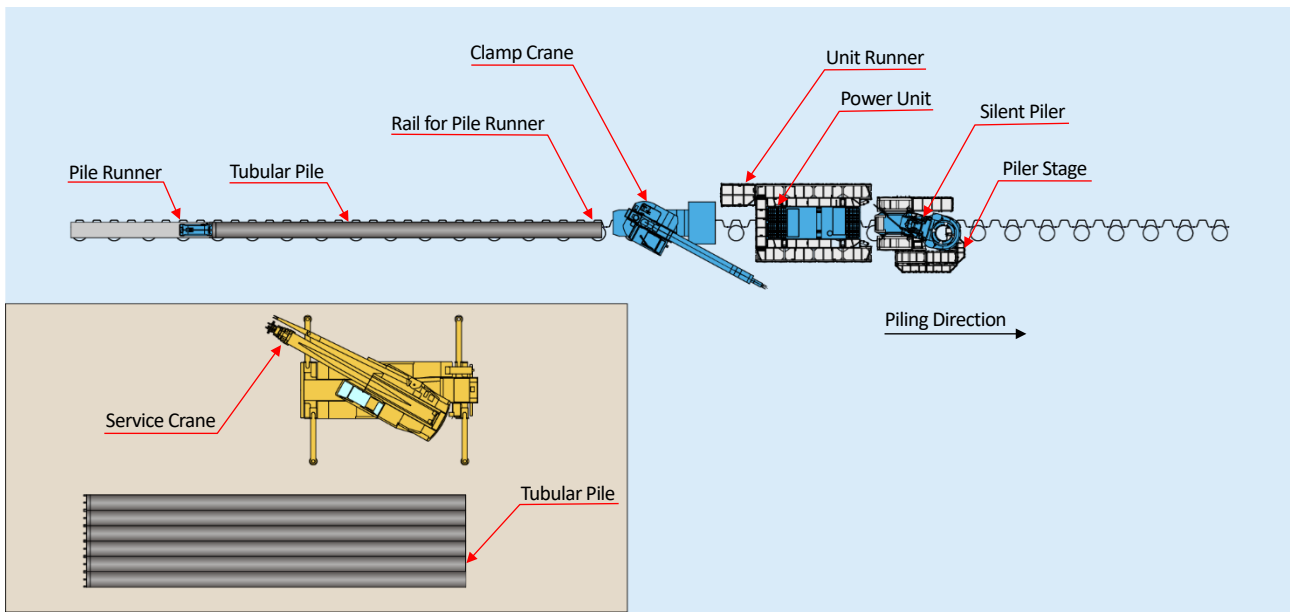

Chapter 4 Machine Specification

4-1 Machine Specification (for Sheet Piling)

4-1-1 Silent Piler F301-900

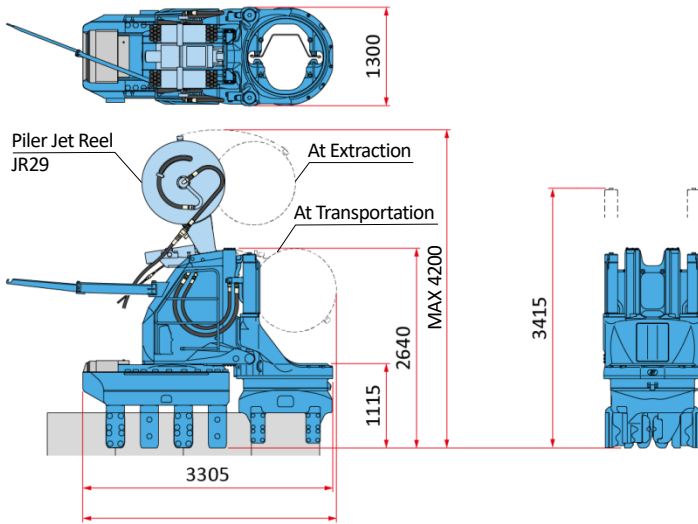

| SILENT PILER | F301-900 | |
|------------------------|---|----------|
| Applicable Sheet Piles | Hat Sheet Pile (900mm wide) (10H,25H,45H,50H) | |
| Max. Press-in Force | 800kN(Super Crush Mode) | |
| | 1000kN(Standard / WJ Mode) | |
| Max. Extraction Force | 900kN(Super Crush Mode) | |
| | 1200kN(Standard / WJ Mode) | |
| Stroke | 850 mm | |
| Press-in Speed | 2.0 ~ 43.5 m/min | |
| Extraction Speed | 1.5 ~ 32.3 m/min | |
| Control System | Radio Control | |
| Mass | Super Crush Mode (Main Body & Hose Reel) | 14880 kg |
| | Water Jetting Mode (Main Body & Piler Jet Reel) | 12250 kg |
| | Standard Mode (Main Body) | 11000 kg |

4-1-2 Silent Piler F301-900 (Combi-Gyro Mode)

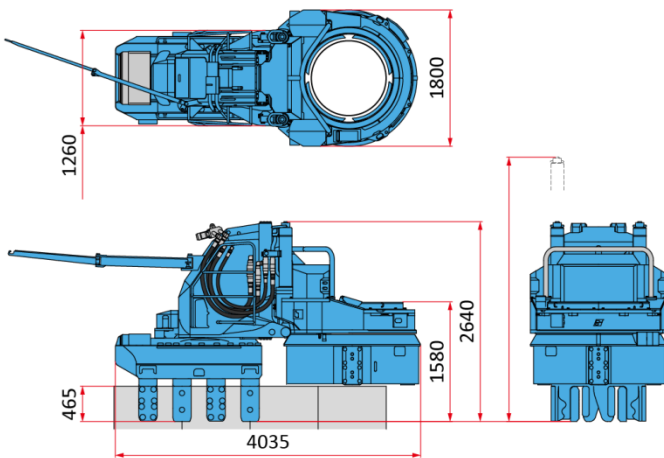

| SILENT PILER | F301-900 (Combi -Gyro Mode) | |
|------------------------|-----------------------------|---|
| Applicable Sheet Piles | Chuck | Tubular Pile \varnothing 600,800,1000mm |
| | Clamp | Hat Sheet Pile (900mm wide) (10H,25H,45H,50H) |
| | | |
| | | |
| | | |
| | | |
| | | |
| | | |

4-1-3 Piler Stage ST51

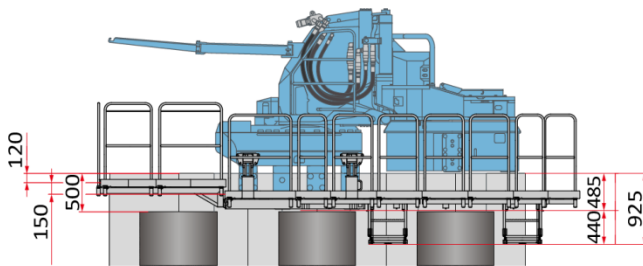
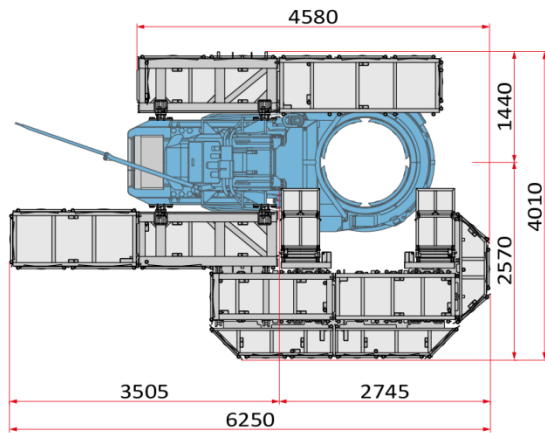

| | |
|---------------|---|
| Piler Stage | ST51 |
| Load Capacity | 300kg (When set both sides) 200kg (When set one side only) |
| Mass | 1270kg |

4-1-4 Power Unit EU300I3

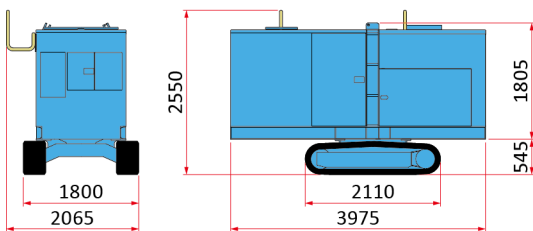

| | | |
|---------------------|-------------------------|--|
| Power Unit | EU300I3 | |
| Power Source | Diesel Engine | |
| Rated Output | Power Mode | 230 kW (313 ps) / 1800 min ⁻¹ |
| | Eco Mode | 204 kW (278 ps) / 1600 min ⁻¹ |
| | Super Eco Mode | 179 kW (243 ps) / 1400 min ⁻¹ |
| Fuel Tank Capacity | 500 L | |
| Hydraulic Reservoir | Piler ECO Oil 490 L | |
| Moving Speed | 1.4 km / h | |
| Mass | 6800 kg (with 30m Hose) | |

4-1-5 Reaction Stand

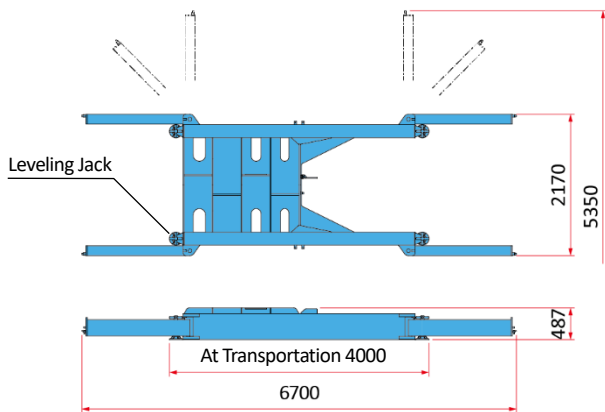

Reaction Stand(with Leveling Jack)

| | |
|------|--------|
| Mass | 2000kg |
|------|--------|

4-1-6 Water Lubrication System OP114A

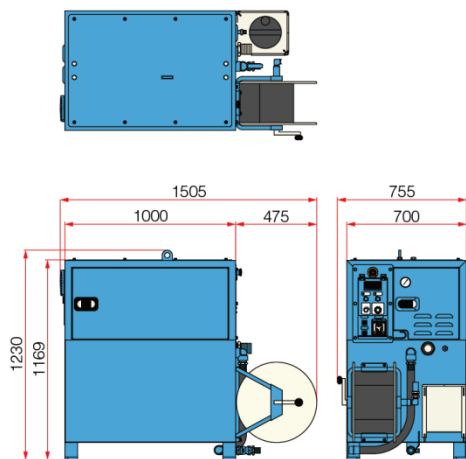

Lubrication System

OP114A

| | |
|-------------------------------|------------------------------------|
| Input Voltage (3 phases) | AC200V, 50 / 60 Hz, 24 KVA or more |
| Water Pump Discharge Rate | Max.60L / min |
| Water Pump Discharge Pressure | Max.6MPa |
| Outer Tank Capacity (W×D×H) | 1505 × 755 × 1230 |
| Water Tank Capacity | 300 L |
| Mass (without water) | 410 kg |

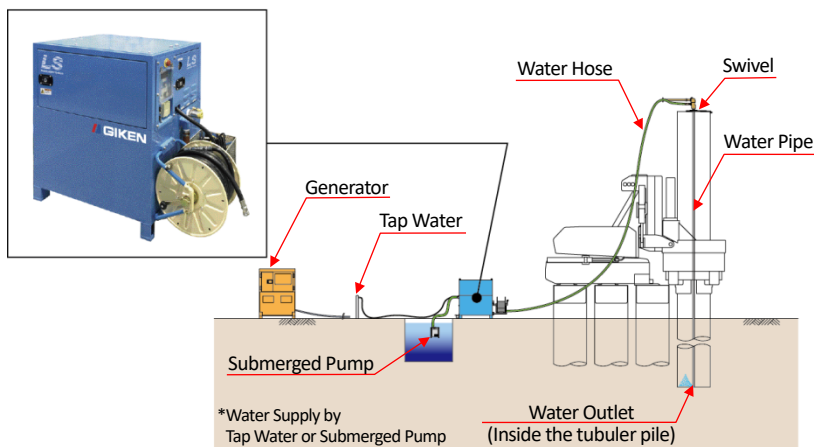

4-1-7 Driving Attachment

Driving Attachment AM69A

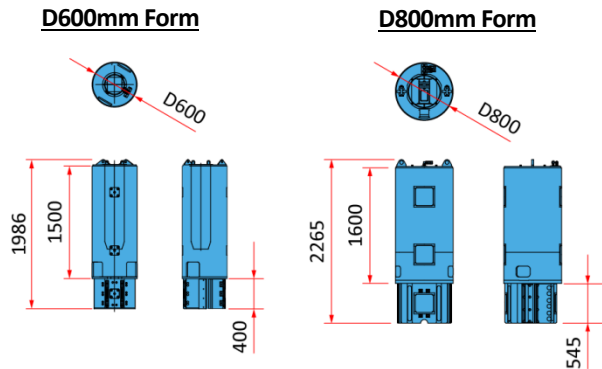

| Driving Attachment | AM69A |
|--|--|
| Applicable Closure Pile (Equal Angle Section) | 200 × 200 × t20 - 25 250 × 250 × t20 - 25 |
| Mass | 1100 kg (D600mm Form) 2000 kg (D800mm Form) |

Driving Attachment AM105

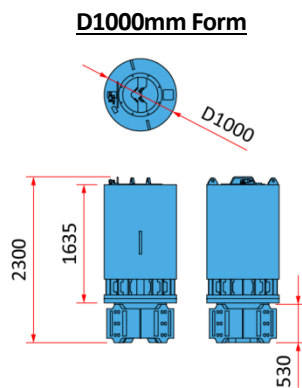

| Driving Attachment | AM105 |
|--|--|
| Applicable Closure Pile (Equal Angle Section) | 200 × 200 × t20 - 25 250 × 250 × t20 - 25 |
| Mass | 3300 kg (D1000mm Form) |

Care has been taken to ensure that the contents of this publication are accurate at the time of printing, but GIKEN LTD. and its subsidiaries do not accept responsibility for error or for information which is found to be misleading. Suggested applications in this technical publication are for information purpose only and GIKEN LTD. and its subsidiaries accept no liability in respect of individual work applications.



Construction Solutions Company

www.giken.com

CONTACT US

