

# GYRO PILER™ F301-G1000

## Dimensions & Specifications

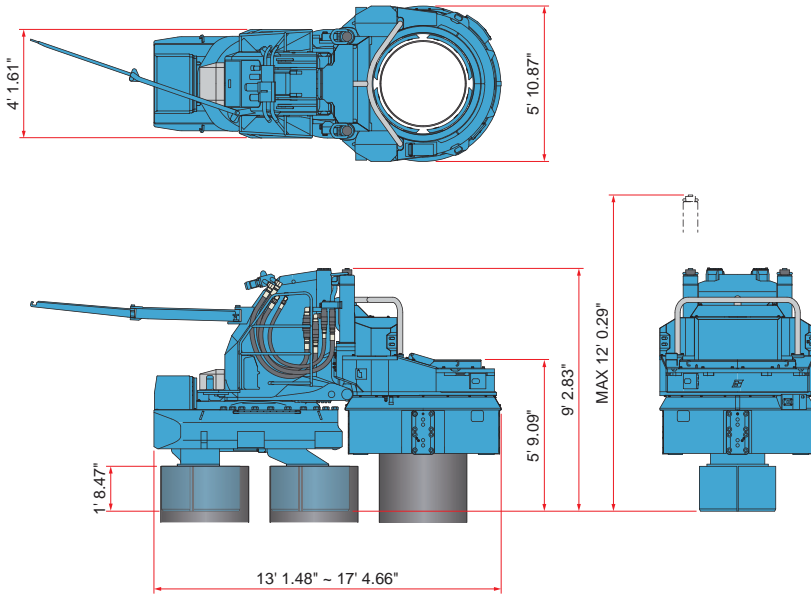

GYRO PILER	F301-G1000
Applicable piles	Tubular Piles D24.00, 32.00, 40.00 in Tubular Sheet Piles D24.00, 32.00 in
Max. Press-in Force	78.6 ton(US)
Max. Extraction Force	95.5 ton(US)
Max. Torque	67.4 tonf·m
Max. Rotation Speed	10.0 rpm
Stroke	33.46 in
Press-in Speed	3.28 ~ 14.10 ft/min
Extraction Speed	4.59 ~ 28.54 ft/min
Control System	Radio Control
Movement	Self-Moving
Mass	35163 lb (for D24.00)
	36486 lb (for D32.00)
	37809 lb (for D40.00)

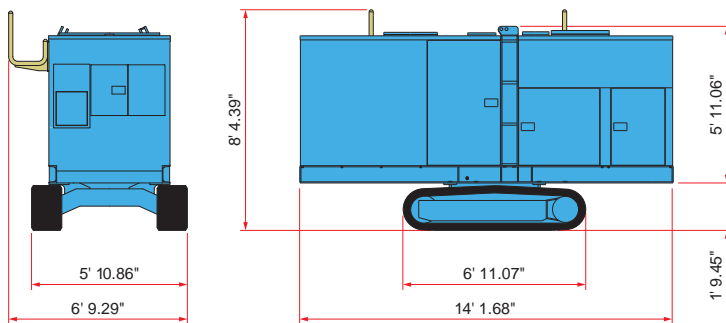

Power Unit	EU300K4	
Power Source	Diesel Engine	
Rated Output	Power Mode	355 HP / 1800 rpm
	Eco Mode	316 HP / 1600 rpm
	Super Eco Mode	276 HP / 1400 rpm
Fuel Tank Capacity	159 US gal	
Hydraulic Reservoir	PILER ECO OIL 166 US gal	
Urea Additive Tank Capacity	10 US gal	
Moving Speed	0.87 mph	
Mass	16644 lb (with 98.42 ft Hose)	

Specifications are subject to alteration without prior notice.