

GYRO PILER™ F301-G1000

Dimensions & Specifications

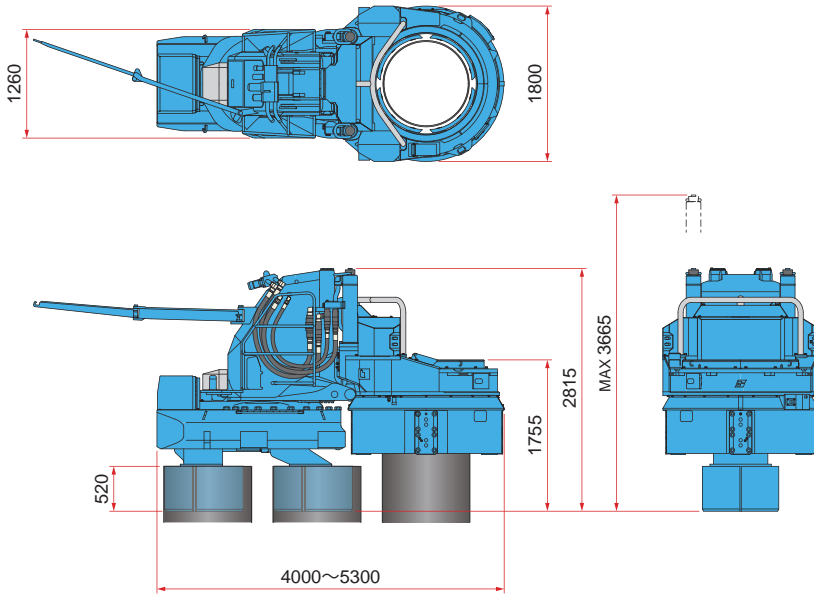

GYRO PILER	F301-G1000
Applicable piles	Tubular Piles D600, 800, 1000 mm Tubular Sheet Piles D600, 800 mm
Max. Press-in Force	700 kN
Max. Extraction Force	850 kN
Max. Torque	600 kN·m
Max. Rotation Speed	10.0 min ⁻¹
Stroke	850 mm
Press-in Speed	1.0 ~ 4.3 m/min
Extraction Speed	1.4 ~ 8.7 m/min
Control System	Radio Control
Movement	Self-Moving
Mass	17600 kg (for D600) 17800 kg (for D800) 18450 kg (for D1000)

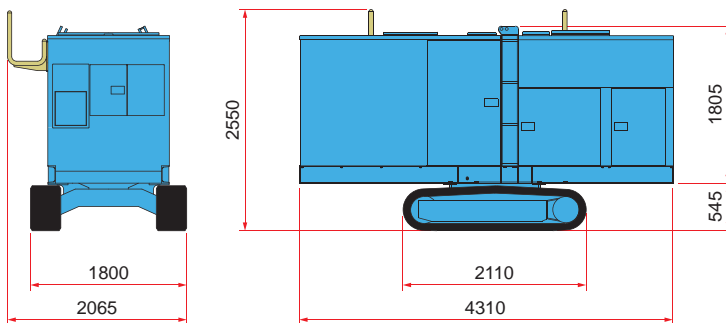

Power Unit	EU300K4
Power Source	Diesel Engine
Rated Output	Power Mode 265 kW (360 ps) / 1800 min ⁻¹
	Eco Mode 236 kW (321 ps) / 1600 min ⁻¹
	Super Eco Mode 206 kW (280 ps) / 1400 min ⁻¹
Fuel Tank Capacity	600 L
Hydraulic Reservoir	PILER ECO OIL 630 L
Urea Additive Tank Capacity	38 L
Moving Speed	1.4 km/h
Mass	7550 kg (with 30m Hose)

Specifications are subject to alteration without prior notice.