

Super Crush Tubular Piler SCP260

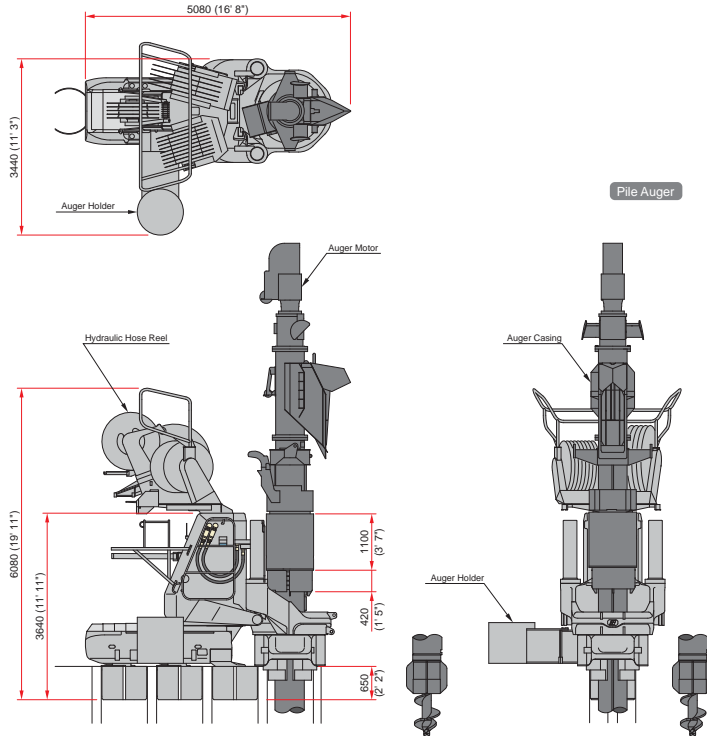

SCP260	Metric Unit	US Standard	
Applicable Piles	D 900 mm	D 36 in	
Max. Press-in Force	2,600 kN (265 tf)	292 tonf (US)	
Max. Extraction Force	2,800 kN (286 tf)	315 tonf (US)	
Stroke	1,300 mm	51 in	
Power Unit Type	EU200 Crawler Unit		
Weight	Silent Piler	28,830 kg	63,600 lb
	Hose Reel	3,000 kg	6,600 lb
	Attachment	1,500 kg	3,300 lb
Total Piler Weight	33,330 kg	73,500 lb	

Pile Auger	Metric Unit	US Standard
Applicable Pile Length	Max. 21 m	Max. 69 ft
Max. Installation Force	650 kN (66 tf)	73 tonf (US)
Max. Extraction Force	700 kN (71 tf)	79 tonf (US)
Stroke	850 mm	33.5 in
Max. Auger Torque	80 kN · m	59,000 ft · lb
Max. Rotation Speed	20 min ⁻¹	20 rpm
Power Unit Type	EU300 Crawler Unit	
Auger Weight	10,200 kg	22,500 lb
Total Machine Weight	Metric Unit	US Standard
Super Crush Mode	43,530 kg	96,000 lb

Specifications are subject to alteration without prior notice.